

TOPIC

GM Vortec V6 and V8 CPI SPIDER FUEL ASSEMBLY DIAGNOSTICS

In the case of GM Vortec CPI engines, the fuel pump is sometimes misdiagnosed as the cause of fuel system failure. A low pressure/no start situation is not necessarily caused by the fuel pump.

A Key On/Engine Off pressure drop could potentially signal a failing CPI unit. The pressure regulator contained within the CPI spider assembly is notorious for failures. Often the regulator diaphragm fails and the plenum fills with fuel and the engine will flood.

The poppets at the end of the tubes require full system operating pressure to open. System operating pressures are 55-61 PSI for 1995 and older vehicles and 60-66 PSI for 1996 and newer vehicles.

POPPET

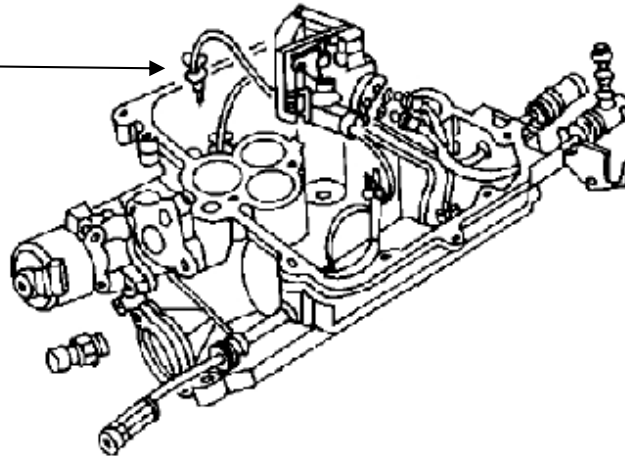

Isolate the CPI unit to determine if a no start condition is caused by a faulty CPI unit or the fuel pump. To rule out the fuel pump and check valve, disconnect the fuel supply line from the fuel filter, plumb a fuel pressure gauge to the fuel line coming from the pump, and energize the pump just long enough to achieve at least the operating pressure. With the pump off, pressure should not drop more than 20 psi. Before replacing the fuel pump, check for full battery voltage at the pump. Without full battery voltage, even a new pump cannot supply the required pressure. Look for melted connectors and wirings when you find low voltage at the pump.

Another common failure with the CPI spider assembly is leaky tubes and poppets stuck closed. Leaking tubes will cause engine-off fuel pressure to slowly drop, creating hard starts. Poppets stuck closed will create an engine misfire from fuel starvation.